

(No Model.)

S. STRUNZ.
BELT SHIPPER.

No. 247,131.

Patented Sept. 13, 1881.

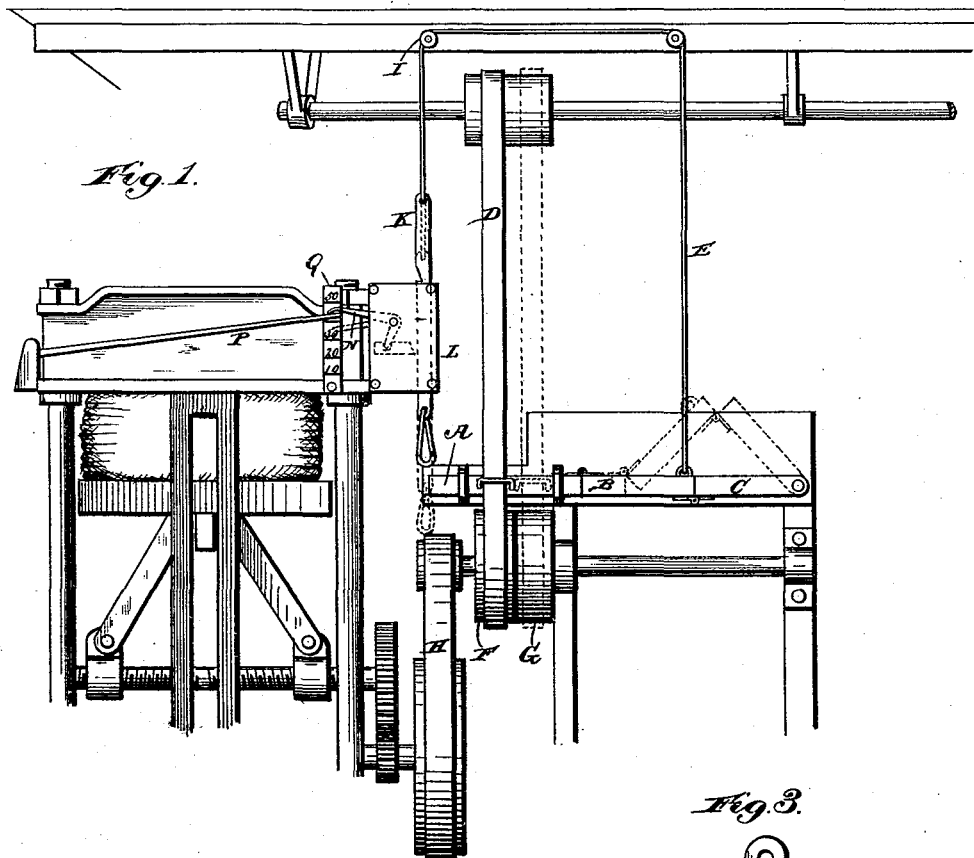

Fig. 1.

Fig. 2.

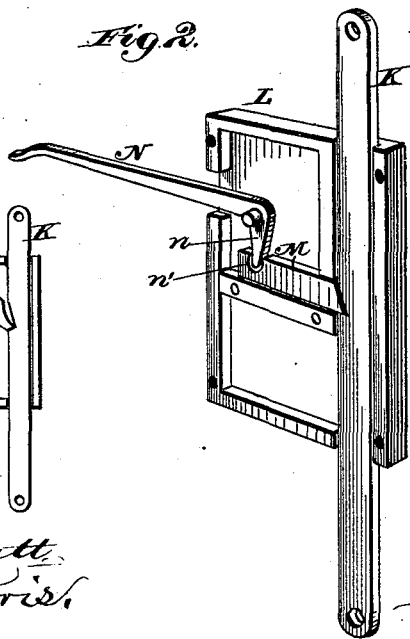
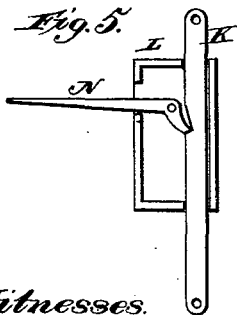

Fig. 3.



Fig. 4.

Fig. 5.



Witnesses.

Robert Everett,
A. H. Norris.

Inventor.

Stephen Strunz,
By James L. Norris,
Atty.

UNITED STATES PATENT OFFICE.

STEPHEN STRUNZ, OF PITTSBURG, PENNSYLVANIA.

BELT-SHIPPER.

SPECIFICATION forming part of Letters Patent No. 247,131, dated September 13, 1881.

Application filed August 15, 1881. (No model.)

To all whom it may concern:

Be it known that I, STEPHEN STRUNZ, a citizen of the United States, residing at Pittsburg, in the county of Allegheny and State of Pennsylvania, have invented new and useful Improvements in Belt-Shippers, of which the following is a specification.

This invention relates to a device that is especially designed to be employed in connection with the belt-shipper secured to me by Letters Patent of the United States numbered 244,336, and dated July 12, 1881, the present object being to provide a device by means of which at any given time it can be automatically actuated by some machine with which it will be connected, so as to cause the operation of the belt-shipper, thereby effecting the shipping of the belt from the fast to the loose pulley and checking the transmission of motion to the said machine, which has primarily actuated the device which constitutes the characteristic feature of my invention.

In the annexed drawings, which illustrate my invention, Figure 1 is a side elevation illustrating the same as applied to a baling-press, and also illustrating the belt-shipper which constitutes the subject of the aforesaid patent. Fig. 2 is a perspective view of my device detached. Fig. 3 shows the slide-bar, and Fig. 4 illustrates a modified form of locking-lever. Fig. 5 is a modification of the locking device.

The belt-shipper consists, essentially, of a jointed bar composed of the three hinged sections A, B, and C, the section A, which slides through suitable guides, being provided with a bail passing around a belt, D, and being hinged to the central section, B, by a hinge on their top sides, the said central section being hinged to the remaining end section by a hinge on their under sides, and the said end section being pivoted at its outer end to a suitable support, so that when the requisite degree of tension is exerted upon the cord E, which is secured to the central section of the jointed bar, the sections B and C will be lifted at their meeting ends, as indicated in dotted lines, thereby retracting the sliding section A and shifting the belt from the loose pulley F to the fast pulley G, in order to transmit motion to the shaft upon which the said pulleys are mounted. In order, now, to secure this cord so

as to maintain the jointed bar in this position, and also so as to automatically release the cord at the proper moment, so as to allow the hinged bar to straighten out and shift the belt from the fast to the loose pulley, in order to check the transmission of motion to the shaft, and consequently stop the machine to which motion may be transmitted from a pulley upon said shaft by a belt, H, I attach to the cord depending from one of the pulleys, I, over which it passes, a slide-bar, K, formed with a notch, L, and arranged to slide along a suitable way in a casing, L, and I engage in said notch of the slide-bar the beveled end of a locking-bolt, M, arranged to slide within said casing. This casing will be attached to some suitable machine—such as a baling or other press, a lathe or other machine—where it has heretofore been found necessary to have an attendant to stop it at certain moments during its operation.

In order to release the bolt from the slide-bar, so as to allow the same to be raised by the tension which the weight of the two raised hinged sections of the shipper will exert thereon, I provide the lever N, that is pivoted to the case and formed with a short arm, n, which is received in a notch, n', in the bolt. The long arm of this lever extends out through the casing, and has sufficient vertical play to admit of the bolt being drawn back and released from the vertical slide-bar when the said long arm of the bolt-operating lever is raised for such purpose. As soon as the bolt has been thus released the slide-bar will be drawn up by the cord, and hence the jointed bar of the shipper will be allowed to straighten out and ship the belt from the fast to the loose pulley. To ship the belt back again it will be only necessary to draw down the notched slide-bar attached to the cord and to operate the lever so as to slide the bolt forward and cause it to engage the notch of the said bar. Now, it will be evident that this lever can be raised at a given time by a variety of classes of machines.

As herein shown, I have illustrated an ordinary press provided with an indicating-rod, P, that will be raised with the follower of the press. This rod can be set with reference to a graduated scale, Q, upon the frame of the press, and the long arm of the bolt-operating lever arranged so that as the rod rises the le-

ver-arm will lie in the path thereof, and hence be raised when the rod reaches the required height. The press will receive motion through belt H from the shaft upon which the fast and loose pulleys before mentioned are mounted, whereby, as soon as the belt has been shipped from the fast to the loose pulley through the agency of the aforesaid indicator-rod and my improved device, the operation of the machinery of the press will be stopped.

In Fig. 4 I have shown the lever having a portion of its long arm bent vertically, this form of lever being used where a horizontal thrust of some portion of the machine with which my device is connected will be required to operate the shipper so as to check transmission of motion to said machine.

In conclusion, I may add that it is obvious that my device might be used in connection with a water-tank, devices within the province of any mechanic being employed in such connection to cause the operation of the belt-operating lever after the tank has been filled to a certain height, and to cut off the flow of liquid therein, or to cause the action of said lever after a certain quantity of liquid has been drawn from the tank, and then to close the cock; also, that the construction of belt-shipper could be considerably changed from that shown and still be adapted to be operated by the means set forth.

As shown in Fig. 5, the pivoted lever may engage directly with the slide-bar, thus dispensing with a locking-bolt. In some cases this may be found desirable, although I prefer the construction hereinbefore described.

Having thus described my invention, what I claim is—

1. The combination, with a machine requiring its motion to be checked at a given time, of the sliding locking-bolt, the pivoted lever engaging said bolt and having one arm ar-

ranged to be operated by the said machine, so as to draw the locking-bolt at the time required for stopping the machine, and the slide-bar adapted to be engaged by said bolt, and arranged upon the disengagement of the bolt to cause the action of devices checking the transmission from the source of power to the machine that has operated said lever, substantially as described.

2. The combination, with a belt-shipper, of a machine arranged to be set in motion or stopped by the action of the shipper, and a device for causing the shipper to automatically act to cause the stoppage of said machine, the same consisting of the slide-bar connected with the shipper-rope, the locking-bolt adapted to engage and hold said slide-bar, and the lever arranged to engage and slide the locking-bolt, substantially as described.

3. The combination, with the notched slide-bar K, of the locking-bolt adapted to engage and lock said bar, the lever N, engaging said bolt, and apparatus for automatically actuating the long arm of said lever and causing it to disengage the locking-bolt from the slide-bar, substantially as described.

4. The combination, with a machine requiring its motion to be checked at a given time, of the pivoted lever, with the sliding bar K, the said bar being adapted to be engaged by said lever, and being arranged so that upon the disengagement of the lever therefrom the devices checking the transmission of power to the machine will be operated, substantially as described.

In testimony whereof I have hereunto set my hand in the presence of two subscribing witnesses.

S. STRUNZ.

Witnesses:

G. STENGEL,
DANL. P. BERG.